

## MOUNTING INSTRUCTIONS

1. First remove cover by unscrewing two bolts holding cover to the can.
2. Remove Xenon bulb by pulling bulb directly outward from bulb socket.
3. Remove reflector by unscrewing one bolt at bottom of "V" in reflector, and gently lifting reflector from around bulb socket and out of the can.
4. Place all parts in a secure location until reassembly.
5. Select a mounting location for the Xenon Step Light. Fixture should be within reach of 110V power, located approximately 9 inches above the floor in a step light location, and situated at the best location along the mounting surface for the illumination task.
6. Cut a 5-1/2" (L), 4" (W), and 2-1/2" (D) hole in mounting surface for the can.

7. Xenon Step Light has wide flanges that will allow the can to be securely affixed to almost any surface with the four mounting screws and wall anchors provided. Place can in hole and mark the position of the four mounting screws. Remove can and drill a pilot hole for the screws, or a hole for the wall anchors. Install anchors ( if applicable ), reposition can in hole, and securely fasten the can to the mounting surface by firmly tightening four mounting screws.

**CAUTION!** Local code may require plywood backing with wood screws (not included) for ceiling mount applications. Check with your local building department before installation.

## WIRING INSTRUCTIONS

**CAUTION!** Only qualified electricians, or people familiar with household electrical circuits, should bring 110V power to the fixture. Wiring may require an inspection by the local building department. Check with your local building department before installation.

**CAUTION!** Before bringing 110V power to the fixture, make sure incoming wire is not "hot" and all power coming to the wire is off.

**CAUTION!** All connections must be made in accordance with this instruction manual, current NEC, and all local building codes. Minimum 90°C supply conductors.

**CAUTION!** When installing in a wet location, use RTV silicone or water-tight fittings on all connections to fixture.

1. Through one of the many knockouts provided, bring in 110V power wiring. If 110V wire will not conveniently enter one of the four knock-outs provided, simply unscrew the can, rotate can 180 degrees and reinstall. Can is entirely symmetrical, and 180 degree rotation will not affect mounting holes.
2. Secure wire to fixture with the appropriate strain relief ( not provided ).
3. Strip 1/3" (8mm) of the insulation off each incoming 110V power wire. Connect white incoming 110V wire (neutral wire) to push-in connector on white wire from transformer. Connect black incoming 110V wire to push-in connector on black wire from transformer. Connect ground wire to push-in connector on green wire screwed into can. Push all wires firmly down into connectors, so that uninsulated wire is not exposed.

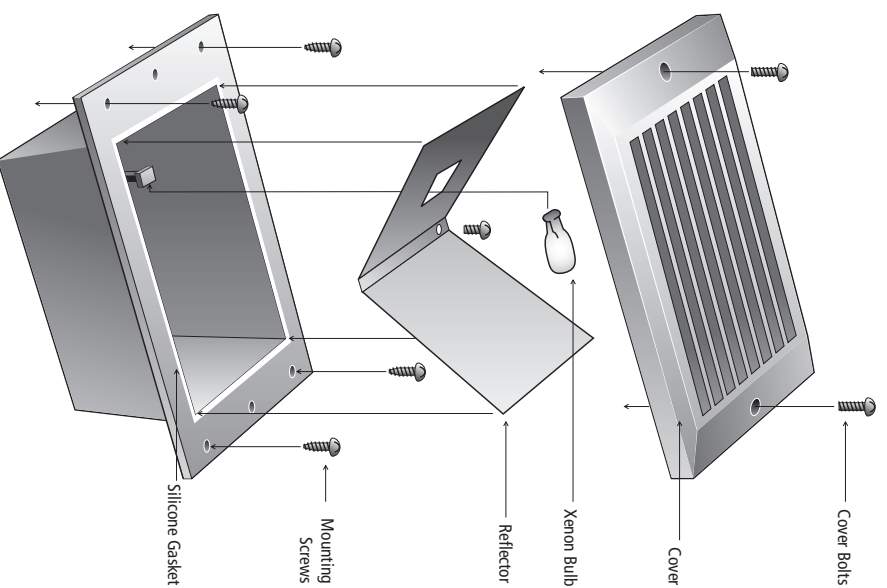

## RELAMPING

**CAUTION!** If Xenon Step Light has recently been operating, glass lens, bulb and fixture are HOT! Turn Off fixture and allow unit to cool for 15 minutes.

**CAUTION!** Always make sure there is NO power coming to the fixture, or 110V power wiring, before relamping!

1. Remove cover by unscrewing two bolts holding can to cover.
2. Remove Xenon bulb by pulling directly outward from the bulb socket.
3. Replace with a 18 watt, 12 volt, wedge base Xenon bulb only (Our model number XEN-12-18W ). Push bulb directly into socket until bulb base is firmly seated.
4. Make sure Silicone gasket is properly in place on top of can. Place cover on can with Louver or Scoop openings pointing toward the illumination surface. Secure cover to can by reinstalling the two screw bolts provided.
5. Re-energize the 110V to the fixture. If bulb does not light, check for a loose bulb in socket by repeating steps #1 through #4 above. If bulb still does not light, retry steps #1 through #4 above with a new Xenon bulb.

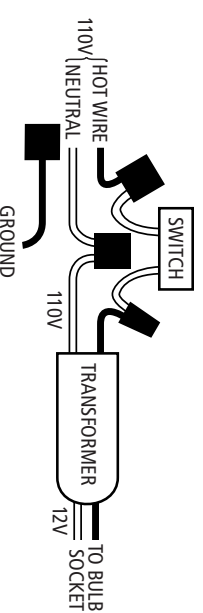

## THROUGH-WIRE, 110V POWER

- Disconnect from all 110V power prior to installation.
- Connections must be made in accordance with all local electric codes and/or NEC.
- Minimum 90°C supply conductors.
- Interconnect up to 1188 Watts (66 bulbs).
- 14 gauge (Romex Type) or better wire is required.

- Requires strain reliefs.
- Installations in wet locations should use RTV silicone or water-tight fittings on all connections to fixtures.

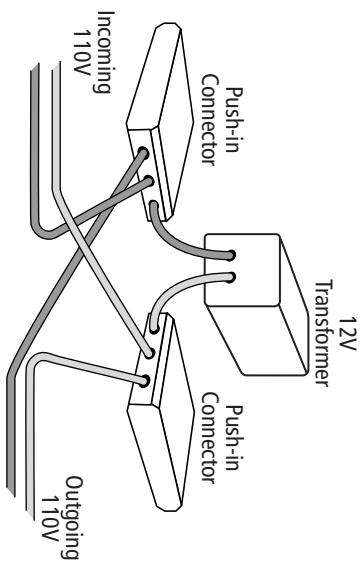
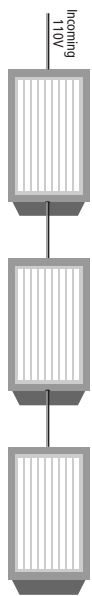

**WARNING!** If this fixture is to be placed in a masonry or brick wall, you must use a Concrete Cap during installation to provide the proper void for the fixture cover. Failure to use the Concrete Cap will almost guarantee concrete or grout forming against fixture can flange, and poor cover-to-can seal (see below). Poor cover seal will allow water/moisture into fixture resulting in LED and Xenon failure.

**Without Concrete Cap**

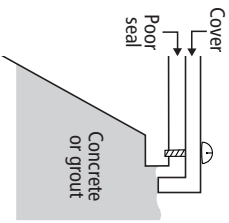

Concrete or grout prevents cover from allowing a proper seal

**With Concrete Cap**

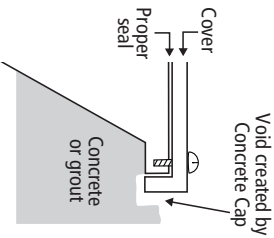

Concrete form used during fixture installation allows for proper void and good cover-to-can seal

**OTHER XENON PRODUCTS BY NSL**

**XENON TASK LIGHT**

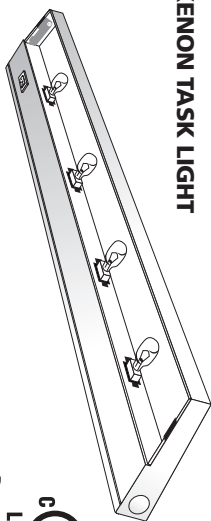

**UL LISTED**  
Damp Locations

The perfect under-cabinet task light fixture. Brighter than fluorescent, a fraction the heat of halogen, and four times the bulb life of halogen.

**XENON MINI LIGHT**

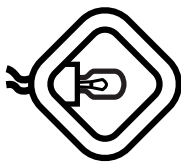

**ETL LISTED**  
US

A completely new design of the industry standard "hockey puck". A fraction the heat of a halogen, four times the bulb life of halogen, similar bright white light.

**XENON PICTURE LIGHT**

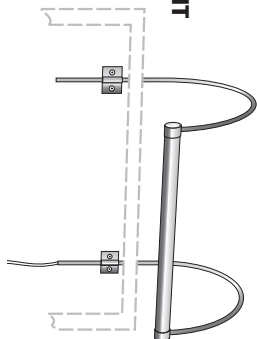

**UL LISTED**  
US

The new benchmark for picture lighting. No picture fading UV's of halogen, greater light output, and four times the bulb life of the competition.

**BRITE STRIP**



**ETL LISTED**  
US

Our brightest, flexible, linear lighting system. Parallel wiring, flexibility and field cutability make Brite Strip the professional's choice for covers, under cabinets, display cases and more.

**INSTALLATION INSTRUCTIONS**

**XENON STEP LIGHT**

The Brightest, Longest-lasting Step Light

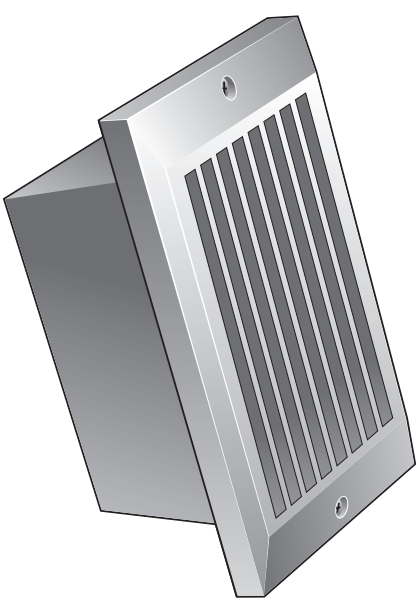

• 10,000-hour bulb life

• Louver, Scoop & Prism cover designs

• White, Bronze, Black and Aluminum colors

• Die cast aluminum design suitable for concrete pour, framed walls, ceilings & showers

• UL Listed for wet locations

**NSL**

NATIONAL SPECIALTY LIGHTING  
ARCHITECTURAL AND DECORATIVE LIGHTING  
LOUISVILLE, CO 80027  
[www.nslusa.com](http://www.nslusa.com)

© 2008 National Specialty Lighting

9/08

**UL LISTED**  
Wet, IC, Ceiling & Shower Locations