

DOUBLE BLAZE™ LED Strip Light

Double BLAZE™ LED Strip Light is a super bright LED strip that is twice as bright as our BLAZE™ LED Strip Light and four times as bright as FLUID VIEW LED Strip Light. This LED tape light is our brightest strip and features two parallel rows of densely-packed, high output LED lights. The Double BLAZE LED Strip light is cuttable every inch.

Each spool comes with both a DC plug and lead wires attached that allow for easy connection to a power source, whether a 12V Plug-In Adapter or Hard-Wired Driver, so it's plug-and-play. It comes with a 3M™ adhesive backing which allows for easy mounting on a clean, dry surface.

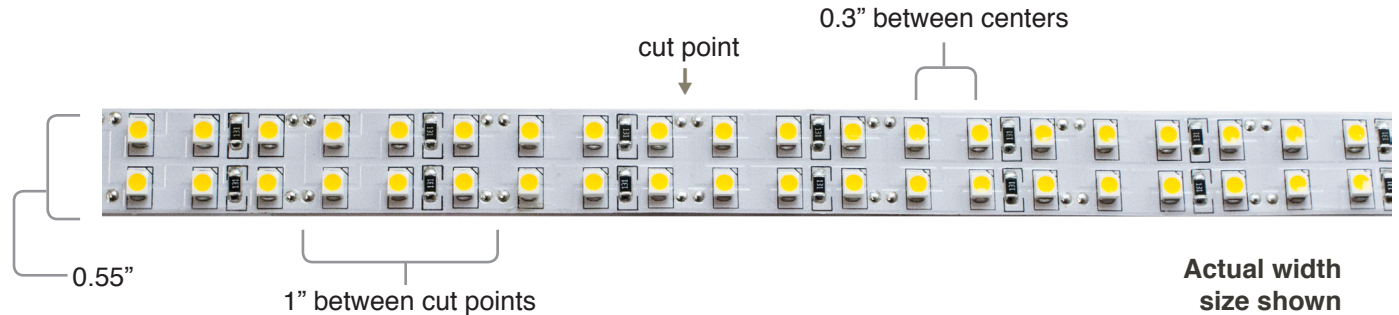

FEATURES

Input Voltage: 12V DC
LED Chip Type: 3528 SMD
Chips per foot: 72
Power Consumption per foot: 6W / 485mA
Rated Fixture Lumens per foot: 480
Luminous Efficacy: 80 lm/W
Field Cuttable: every 1 inch
LED Spacing: 0.3 in. (between centers)
Width: 0.55 in.
Height: 0.1 in.
Spool Length: 16.4 ft.
Max. Run: 16.4 feet
** Each maximum run requires a dedicated line from the power supply to avoid voltage drop.*

Certifications: UL Listed, RoHS
Dimmable: yes
Environment: Indoor
Warranty Period: 5 years (*limited*)
Operating Temp.: -22° - 103° F
Mounting: 3M Adhesive Sticky Backing
Rated Lamp Life: 50,000 hours
Connectors: Spool =12 in. DC plug on one end, 3 ft. 18/2 lead wires on the other end.



TECHNICAL SPECIFICATIONS

item #	length	color	color temp.	lumens / ft.	beam angle	power consumption / ft.	CRI	LEDs / ft.
DI-1340	16.4'	warm white	2700k	480	120°	6W / 485mA	75	72
DI-1341	16.4'	cool white	5000k	480	120°	6W / 485mA	80	72

APPLICATIONS

- Kitchen cabinet, under cabinet, shelf, and case lighting
- Exhibit, presentation, and project lighting
- Close application task lighting
- Cove and interior accent lighting
- Shop windows, window displays, display case lights, and uplighting
- Light boxes and interior signage

IN USE PHOTO



INSTALLATION



Double BLAZE Strip Light Splice Connector
item #DI-0811
Connects Double BLAZE Strip Light to wire leads.



Double BLAZE Strip Light DC Plug Connector
item #DI-0812
Connects Double BLAZE Strip Light to a DC plug-in adapter.



Double BLAZE Strip Light Bending Extension
item #DI-0813
Connects two Double BLAZE Strip Light sections together at variable angles.



Double BLAZE Strip Light Bending Extension
item #DI-0814
Connects two linear sections of Double BLAZE Strip Light sections together.

Install the Double BLAZE High Output Strip Light on a clean, dry surface by peeling the protective layer from the 3M™ adhesive backing and attaching the strip from one end, keeping it taut to prevent bumps and to ensure a straight installation.

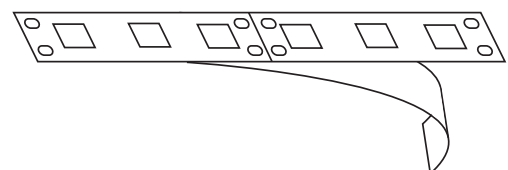

PLUG-IN ADAPTER WIRING DIAGRAM

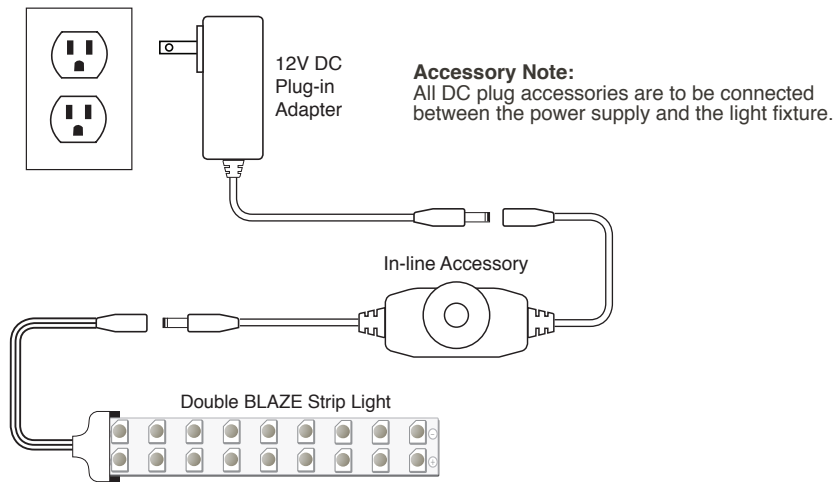

HARDWIRE WIRING DIAGRAM

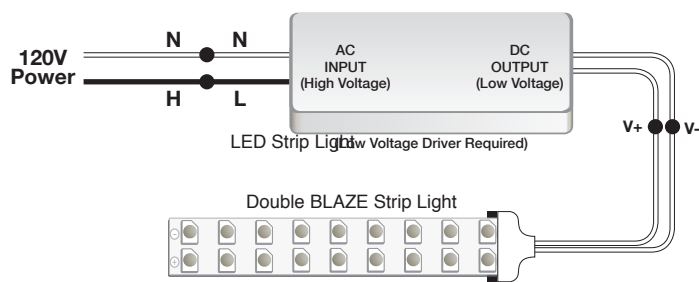

DIMMING WIRING DIAGRAM- REIGN 12V-24V DIMMER SWITCH

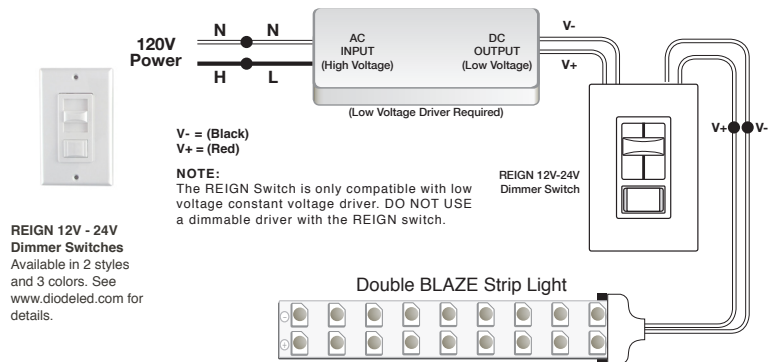

120V MAGNETIC LOW VOLTAGE DIMMER SWITCH WIRING DIAGRAM

Standard Dimmable Driver Configuration*

*Only use recommended 120V MLV dimmer switches. See the compatibility list for a detailed list of compatible dimmers.

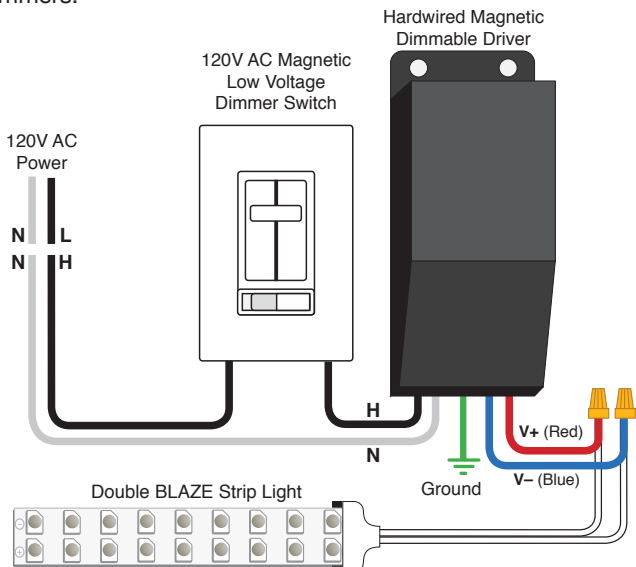

N= Neutral / L= Line / H=Hot

3-Way Dimmable Driver Configuration*

*Only use recommended 3-Way dimmer switches for 3-Way dimming applications. See the compatibility list for a detailed list of compatible dimmers.

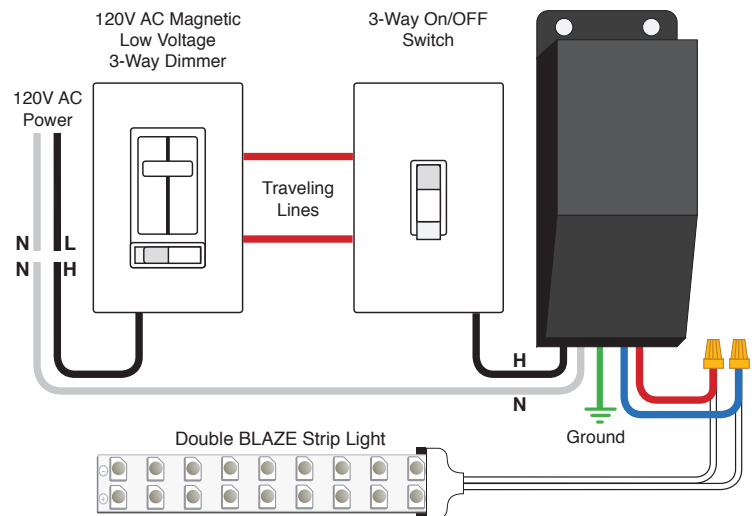

N= Neutral / L= Line / H=Hot

WARNINGS 

1. **Always** consult a qualified, licensed electrician prior to the installation of this product. Diode LED recommends that a qualified, licensed electrician perform the installation of this product.
2. **Always** pre-test your strip light assembly by making all connections and connecting the strip to a power supply and ensure that all components are joined properly before they are installed.
3. It is recommended that adequate airflow and heatsink be taken into account in the application and installation of this product. Improper thermal management may lead to premature failure.
4. Exceeding the operating temperature values may damage LED chips by reducing the total lamp life and lumen output, and inversely impact color consistency.
5. Each maximum run requires a dedicated line from the power supply to avoid voltage drop.
6. This product should only be cut at “cut points,” which are designated with a scissor icon.
7. “Voltage drop” is a gradual lessening of power through a wire over a long distance. The farther the light is from the power source, the more voltage drop will occur. Voltage drop becomes a significant factor in any LED light application when the distance between the lights and the power source is greater than 30 feet. Consult a licensed electrician and an online voltage drop calculator to learn what gauge wire will work best for your configuration. For more tips, visit the Tools & Resources section on www.DiodeLED.com.
8. The manufacturer rates each power supply for maximum power output at optimum thermal and voltage conditions. As with any power supply, true actual maximum continuous current output depends upon various environmental factors such as ambient temperature, line voltage fluctuations, and orientation that may affect heat dissipation. For optimum performance, make sure the load is between 50% and 80% of the total capacity of the power supply.
9. Actual color may vary from what is pictured on this sheet and other Diode LED print materials due to the limitations of photographic processes.
10. LED products are continuously being improved upon in ever-shortening manufacturing cycles. LED color temperature (kelvin), lumen output, and product appearance can change from order to order. Please note that variation in color temperature (kelvin) is commonly +/- 250k and brightness (lumens) is +/- 10%.
11. Diode LED reserves the right to modify the design of our products as part of the company’s program of continuous improvement. Diode LED cannot guarantee to match existing installed product for subsequent orders or replace the product exactly to match the product you are replacing in product appearance, color, or brightness. Specifications are subject to change without notice.

WARRANTY

Limited Warranty: This product has a five (5) year limited warranty from the date of shipment. The complete warranty details are posted on the website at www.diodeled.com under the tools and resources tab. Specific warranty periods can also be found on the individual published Product Specification Sheets.

If you have any warranty related questions please contact Diode customer service at info@doideled.com or call (877) 817-6028.